

Feature

Culross Street London W1

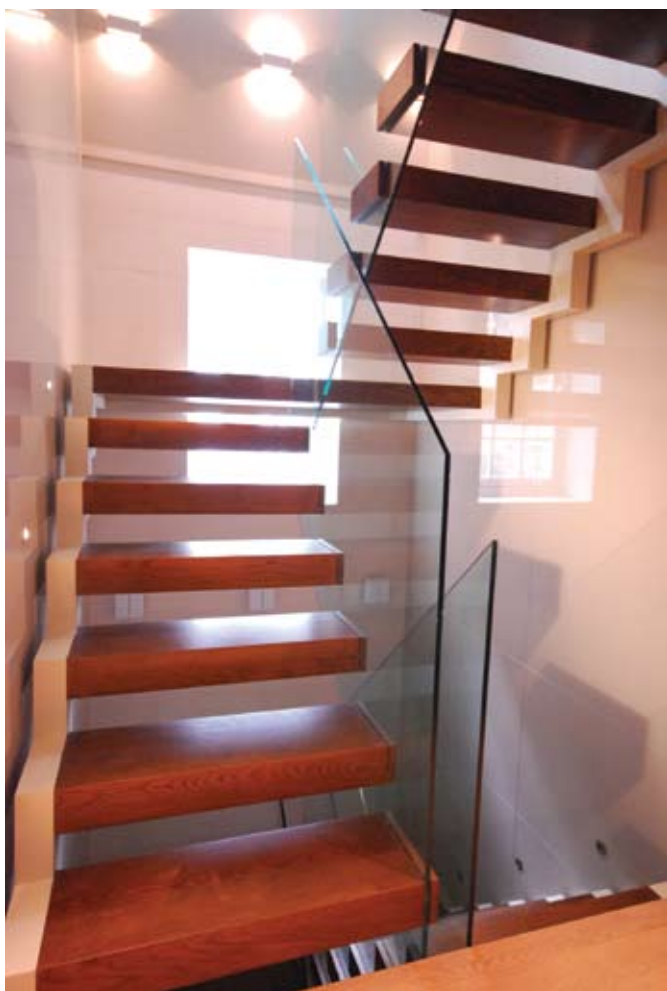

The brief : Cantilevered Stairs _ self supported without fixings to side walls

Having been commissioned to create a set of stairs to a converted five storey luxury Mayfair property, the brief was to create an open riser cantilevered stairs – “self supported without any fixing to side walls.”

The Design team was set the challenge of producing a set of scissor cantilevered stairs that had to be self supported, with emphasis focused on intricate detailing, luxurious and exquisite finishes.

The final solution was this visually stunning set of stairs, comprising of a freestanding cranked steel stinger, hard wood treads, complimented with an internal glass balustrade.

The absence of any side fixings gave the impression that the staircase was floating within its environment.

Design Development

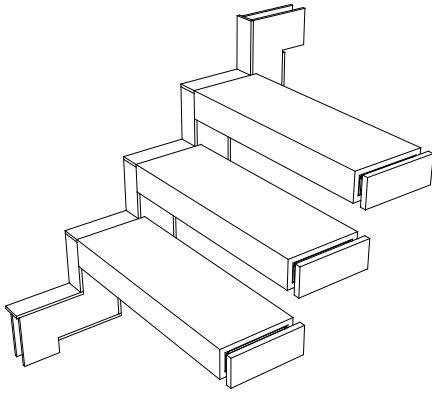

One of the challenges was to develop and introduce a light steel outer carrier that provided the structural integrity for both treads and the glass balustrade.

While putting all of our knowledge and experience to the task, we made the stringer both a sculptural and visual feature of the stairs.

The main structure consists of one self supported zigzag stringer profile, spanning the full outer length of the stairs.

The stringer was fabricated as a mild steel monocoque structure, providing a one sided support for the cantilever steel treads

Fabrication _Installation

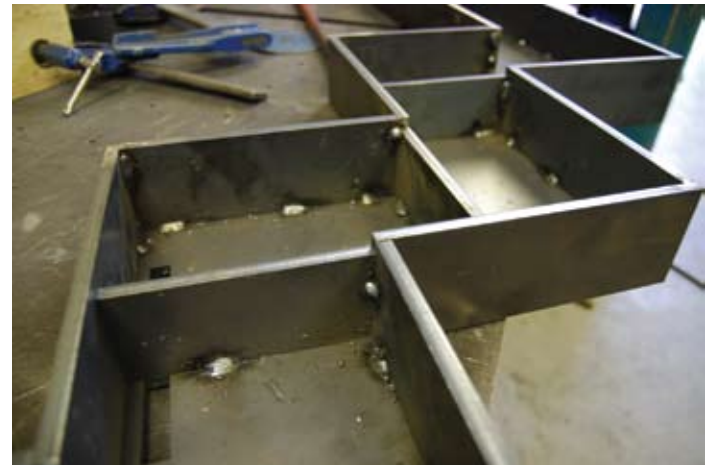

The staircase is open riser, clad with solid oak steps; the structure is fabricated in mild steel with a powder coated finish. The treads are made from folded steel trays, including associated glass clamps, fully clad with American White Oak so as to appear as if a solid piece.

Glass balustrade to stairs and landing are free floating, secured to the edge of the floating treads. The zigzag box steel stringer was finished in white to blend in harmoniously with its surroundings, while subtle low level lighting helped to highlight the path.